

Make a Gratzel Cell Instructions: Make a cell the way scientists do in the lab but using household items such as raspberries!

Making a Grätzel Cell Instructions

Introduction

Solar cells use light from the sun to produce electricity. Using some simple materials we can make a type of solar cell called a '**dye-sensitised solar cell.**' This type of cell is newer and cheaper than those we see on the roofs of houses, and can even be used to make flexible solar panels!

To make the dye-sensitised solar cell we will prepare two halves of the cell and then put them together. One half is called a '**working electrode**' and the other is called a '**counter electrode**'.

General point

Remember to **hold the glass by the edges** as much as possible so that you don't damage the surface of the glass.

Materials you'll need

Chemicals and specialty materials

2 x FTO glass slides (conducting glass – see Equipment List for more details)

template for sticking down slides

titanium dioxide (titania) paste

iodine solution

2-3 raspberries

General equipment

1 x beaker (any size)

1 x beaker of water

1 x crystallising dish

1 x spatula

2 x pipettes

1 x glass rod

tweezers

graphite pencil

scotch tape

multimeter

2 x crocodile clip leads

torch

hot plate set to about 120 °C

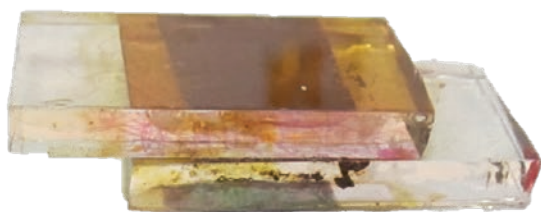

This is what your finished solar cell will look like

Step 1: Check which side of the glass is conducting

- Set the multimeter to 2000 Ω . You should see a '1' displayed.
- Take one of the glass slides. Touch one side with **both** ends of the two probes connected to the multimeter, as shown in the picture to the right.
- If the value stays at 1, this side of the glass is **non-conducting**. Turn the slide over.
- If the value on the multimeter changes, this side of the glass is **conducting**.

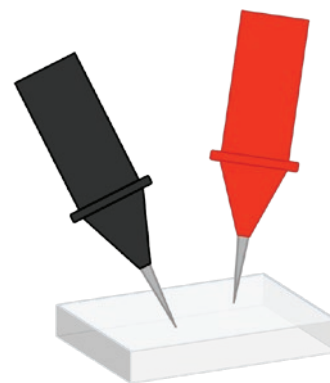

If this is displayed, it means that you are touching the probes to the *non-conducting* side of the glass. Turn the slide over.



If you see a number displayed on the multimeter, you have the slide conducting side up

Important! Make sure you use the **conducting** side of the glass for the next step, otherwise your solar cell will not work!

Step 2: 'Doctor blading' the titania paste onto the working electrode

- Place the glass on the template provided with the **conducting side facing upwards**
- Use scotch tape to tape the glass onto the template provided - make sure the tape is pressed down onto the glass firmly, but only gently secured to the template

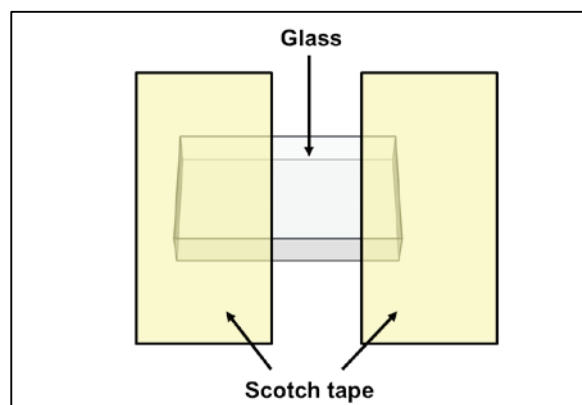

- Use a spatula to place a thick line of white titanium paste on ONE edge of the exposed glass as shown in diagram 1 below.

d) Using a glass rod, spread the paste to cover all of the exposed glass. Press down **firmly** and pull the glass rod slowly towards you to smear the titania paste in **one motion**, as shown in diagrams 2-4 below.

Tips

- **DO NOT ROLL THE ROD.**
- The thinner the layer the better. Thick layers will flake off in the next step
- Try to avoid having gaps in your layer – a thin, uniform layer is the best.
- Don't worry if it doesn't work the first time! Just wipe it off with a tissue and some water and try again.

e) Un-tape the glass electrode from the template and carefully remove the tape. Make sure you don't touch the titania layer.

f) Using **tweezers** to carefully lift the slide, place the glass electrode onto a hotplate and leave for 10 minutes. **BE CAREFUL: THE HOTPLATE WILL BE HOT!**

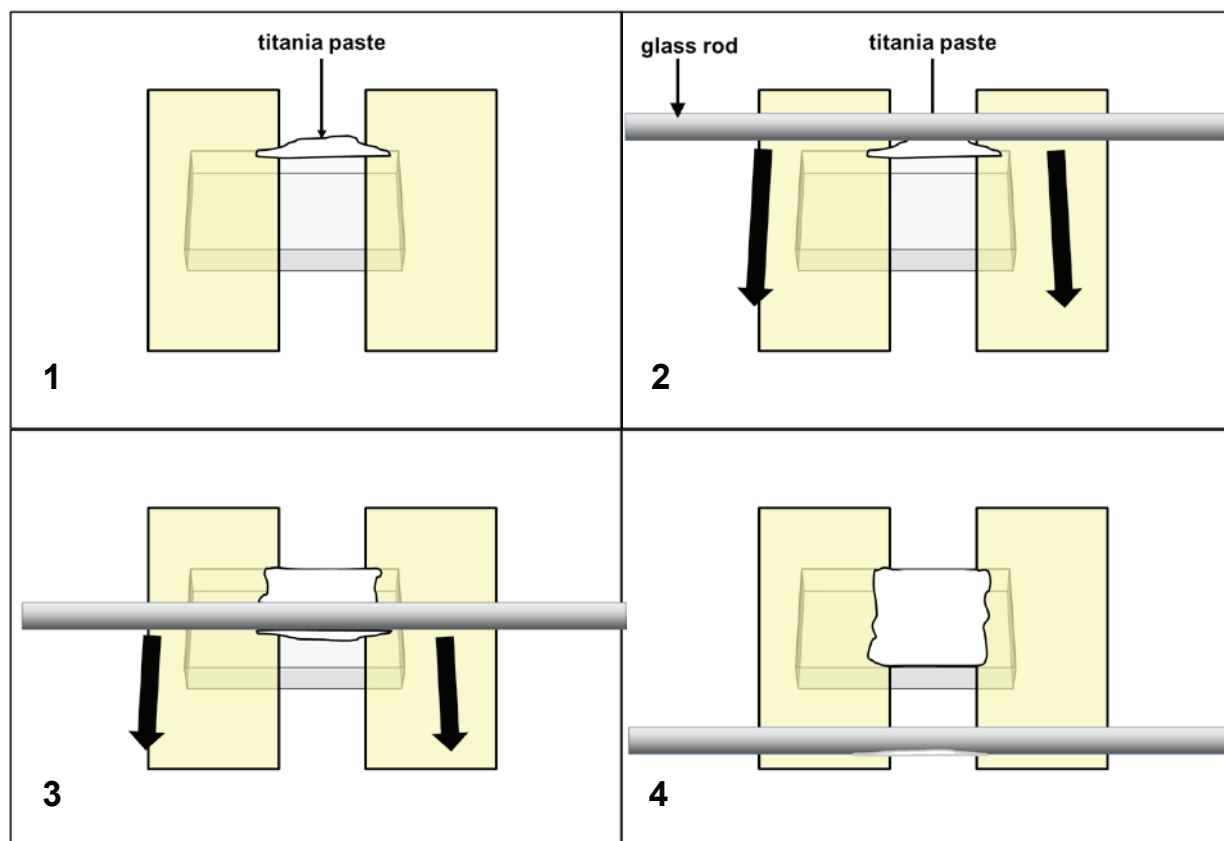

Step 3: Preparing the dye bath

- Take 2 or 3 raspberries and put them in the crystallising dish.
- Using a spatula or glass rod, crush the raspberries up to let the juice out.

Step 4: Preparing the counter electrode

- Take the second glass slide and determine which side is **conducting** as you did in Step 1.
- Use a pencil to 'colour in' the **conducting** side of the glass. Try to cover all of the glass in pencil. This is your '**counter electrode**.'

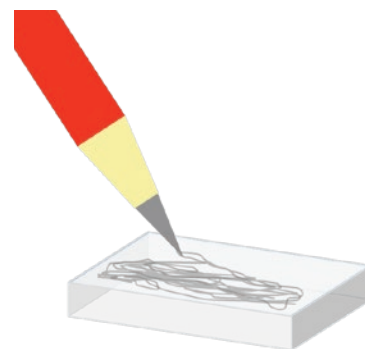

Step 5: Dying the titania paste

- After 10 minutes of heating, use **tweezers** to take the '**working electrode**' off the hotplate.
BE CAREFUL: THE GLASS WILL BE HOT! Allow to cool for 1 minute.
- Again using tweezers, place the '**working electrode**' in the crystallising dish.
- Use a spatula to place the crushed raspberries and juice on top of the electrode. Make sure all of the white titania layer is covered in juice.
- Leave to dye for 5-15 minutes.
 - The longer you leave it in the dye bath, the better your cell will work! It is best to leave it for 15 minutes but if you don't have time, a 5 minute dye bath will work*

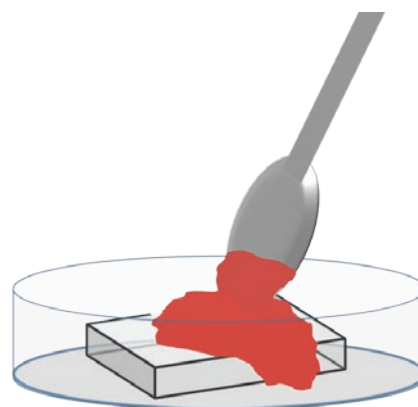

Step 6: Rinsing the 'working electrode'

- Use your tweezers to lift the '**working electrode**' out of the dye bath, taking care not to touch the titania layer.
- Hold the '**working electrode**' over an empty beaker or crystallising dish and, using a pipette and some water, **carefully** rinse off the excess raspberry juice.
- Carefully and gently **pat** the glass slide with a paper towel to dry it.
 - DO NOT RUB** the glass slide, or you will remove all of your titania!

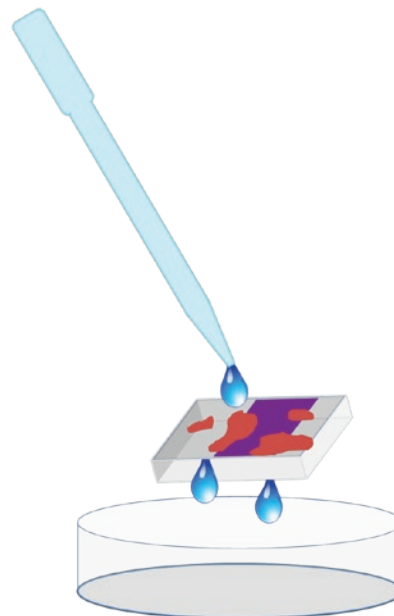

Step 7: Adding iodine solution

- Using a pipette, take up a small amount of the iodine solution.
- Place one drop of the iodine on top of the titania layer as shown below. Once the iodine solution has been placed on the titania layer you will need to work quickly or the iodine will evaporate!

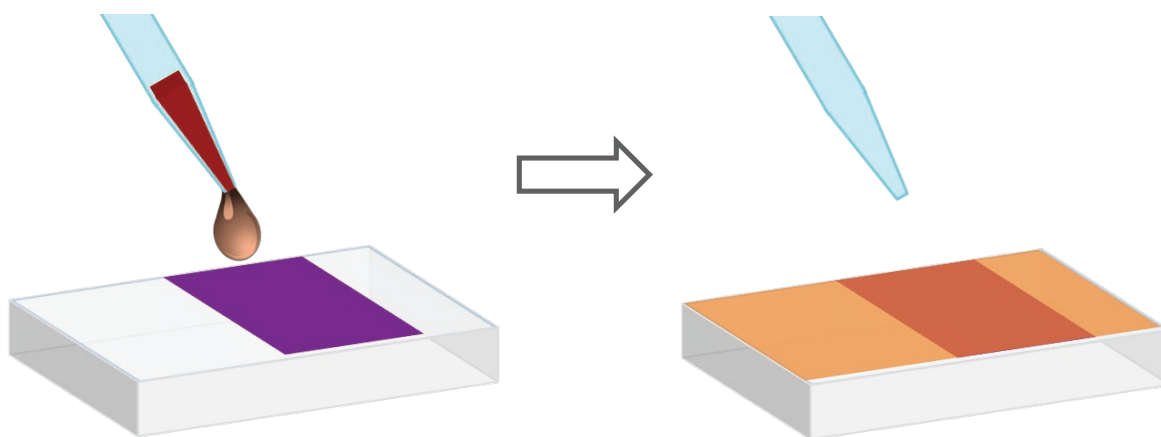

Step 8: Assembling the solar cell

- a) Take the '**counter electrode**' (with the graphite from the pencil on one side) and put it on top of the '**working electrode**' so that the graphite and dyed titania are touching.

The slides should be slightly **offset**, as shown in the diagram. This will allow you to connect the crocodile clips to your solar cell.

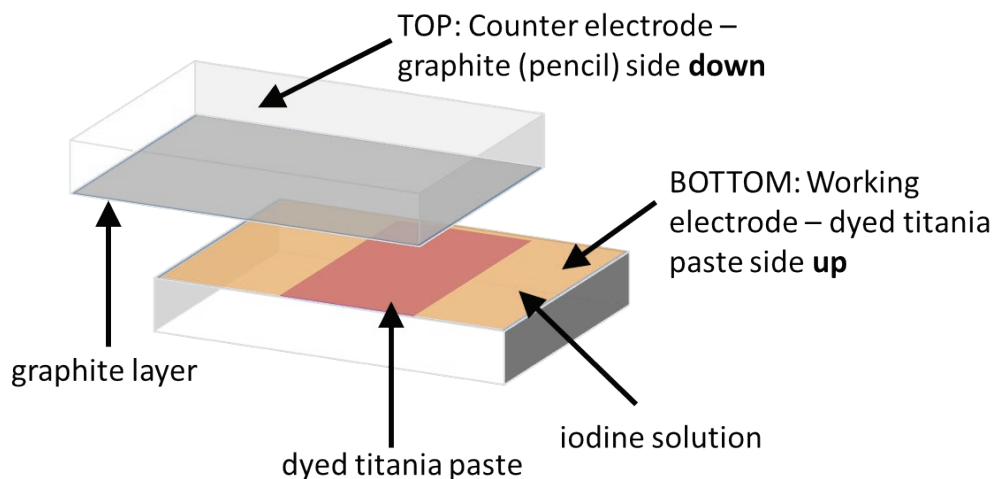

- b) Put a bull dog clip on each of the **long** edges of the cell, to hold it together.

You've just made your solar cell! Now, we need to test it.

Step 9: Testing the voltage

- a) Take the multimeter and turn the dial to 200m V.
- b) Attach a crocodile clip lead to the red wire coming out of the multimeter. Do the same with another crocodile clip and the black wire.
- c) Attach the other ends of your crocodile clips to your cell. Clip one of the wires to the short edge of the **top electrode**, and the other wire to the short edge of the **bottom electrode**, as shown in the picture below.
- d) Record the value you see in normal light and then shine the torch on the cell and record the value you see in bright light. Which is higher?

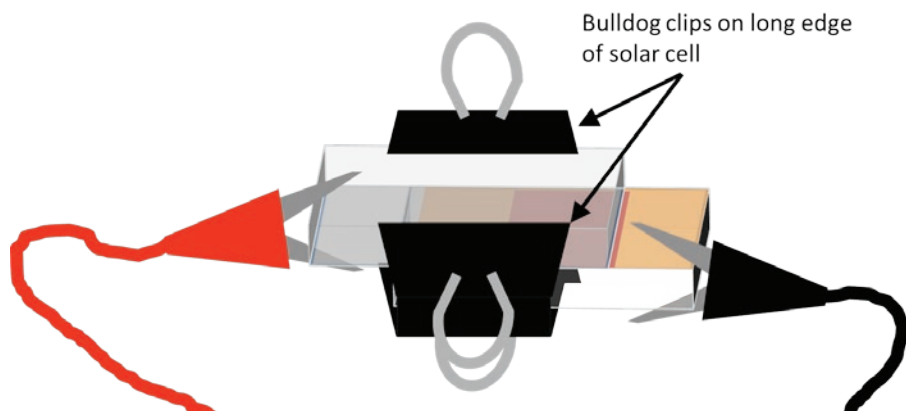

Step 10: Testing the current

- Turn the multimeter dial to 200 μA
- Record the value you see in normal light and then shine the torch on the cell and record the value you see in bright light. Which is higher?

Solar cell not working?

There are a few things which may result in your solar cell not working. These include:

- Not enough iodine solution – if the iodine solution has dried up, the electricity will not be able to flow through your cell. Take the two electrodes apart and place another drop of iodine on top of the titania layer. Re-assemble the cell and see if it works
- The titania layer has come off – if the layer you made in Step 2 was too thick or not even, it can flake off during Steps 5 and 6. It is this layer that absorbs the sunlight, so if there is none left the cell will not absorb any and so cannot generate electricity!
- Conducting glass side down – did you make sure to check **both** slides and keep the conducting side 'up' in Steps 2 and 4?

Clearing up!

The materials we have used today are not dangerous which is why they are perfect for use in solar cells.

- Wash all dirty equipment with water and leave it to dry.
- Extra raspberry juice can be disposed of down the sink.
- Extra iodine solution in your pipette can also be disposed of down the sink.
- Any spillages must be wiped up using moist paper towels.
- Put all equipment back in its place.
- If you are not going to keep your solar cell dispose of it in a glass bin.



ROYAL SOCIETY
OF CHEMISTRY

www.thesolarspark.co.uk
Email: contact@thesolarspark.co.uk



The
Solar
Spark

