

OLDEST PAPER

Name: School Year:

School:

Answer all questions in the spaces provided.

Write your answers clearly. Show all working.

The total marks allocated to the paper are 40 marks (Section A 10 marks, Section B 30 marks)

The time allocated to the paper is 30 minutes.

SECTION A General chemistry knowledge

NOTE In general don't penalise spellings unless specifically indicated.

1. Circle all of the following elements that exist as diatomic molecules. (1 mark)
 ½ mark for each correct answer; ½ mark deducted for each incorrect answer down to zero.

helium

nitrogen

chlorine

sulfur

2. Calculate the relative formula mass of Mg(OH)₂. (1 mark)
 (Relative atomic masses: Mg = 24, O = 16 and H = 1)
 24 + (2 × 16) + (2 × 1) = 58.....

3. State the charge (i.e. +1, +2, -1, -2 etc.) on each of these complex ions; (3 marks)
- Ammonium, NH₄[?] +1.....
- Sulfate, SO₄[?] -2.....
- Carbonate, CO₃[?] -2.....

4. The process of **fracking** is associated with the extraction of which gas from natural resources?
Methane / CH₄ / natural gas.....(1 mark)

5. Balance the following equation for the decomposition of the explosive TNT. (1 mark)
-C₇H₅N₃O₆ →7/2.....C +7/2.....CO +5/2.....H₂O +3/2.....N₂
 or2.....C₇H₅N₃O₆ →7.....C +7.....CO +5.....H₂O +3.....N₂

6. Complete the dot and cross diagram to represent the bonding in hydrogen peroxide, H₂O₂.

(1 mark just for correct number of electrons in correct places)

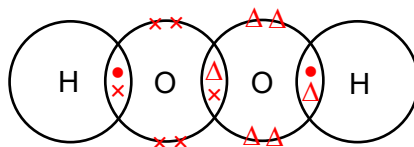

7. Name the scientist who discovered that electrons orbit the nucleus of an atom in distinct energy levels or shells. (1 mark)

Niels Bohr.....

8. Which of the following is not a consequence of global warming. (1 mark)

SECTION B Questions linked to this year's theme of Materials

9. This question is about metals, their properties and uses.

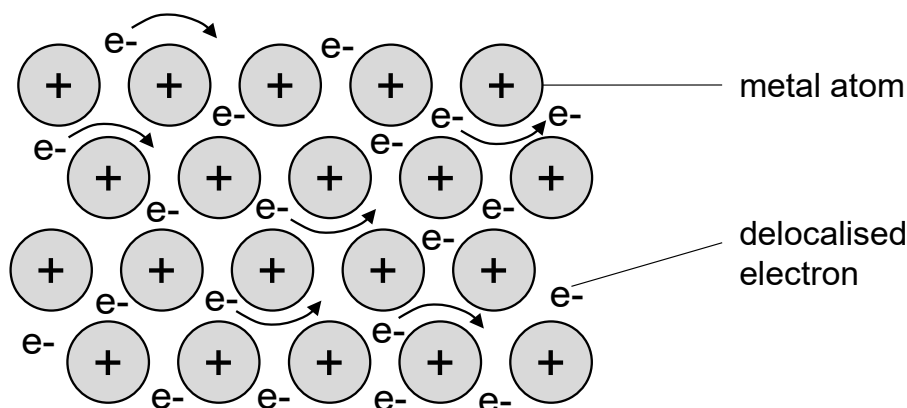

The diagram below shows the bonding in a metal.

(a) State one property of a metal.

Use an understanding of the bonding in the metal to explain why the metal has this property. (2 marks)

Property (1 mark)	High melting point	Conduct electricity	Malleable
Explanation (1 mark)	<u>Strong metallic bonds / strong attraction between positive metal centre and negative electrons</u>	<u>Delocalised electrons are free to move to carry the charge</u>	<u>Layers of atoms can slide over each other</u>

(b) Metals are held together by metallic bonds. This is the electrostatic attraction between the positive metal centre and the negative delocalised electrons.

Predict which of the two metals lithium and sodium will have the higher melting point.

Explain your answer. (3 marks)

*Metal with higher melting point **Lithium** (1 mark)*

*Explanation **Lithium atom is smaller / smaller atomic radius** (1 mark)*

Therefore there is a stronger attraction between the +ive metal centre and -ive electron.
(1 mark)

- (c) The table below provides some information about the materials used to make the Olympic medals for the recent 2018 Winter Olympics in PyeongChang.

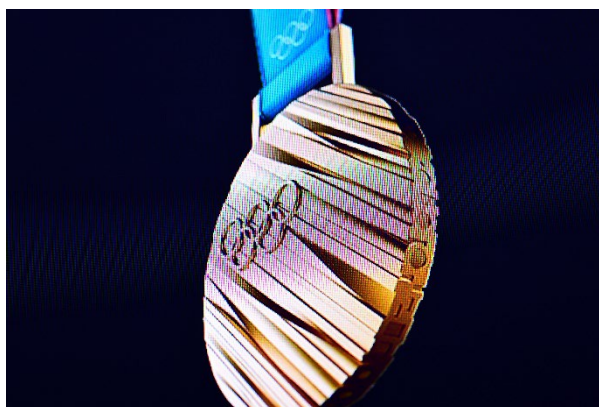

© By Vytautas Kielaitis / Shutterstock

Medal	Composition	Overall mass in g
Gold	A silver medal with a purity of 99.9% plated with 6 g of gold	586
Silver	Solid silver medal with a purity of 99.9%	580
Bronze	An alloy made of 90% copper and 10% zinc by mass	493

- i. What is the mass of copper in a bronze medal? (1 mark)

$0.9 \times 493 \text{ g} = \underline{443.7 \text{ g}}$ or $\underline{444 \text{ g}}$

- ii. What is the mass of silver in a gold medal? (1 mark)

$586 \text{ g} - 6 \text{ g} = \underline{580 \text{ g}}$

- iii. If silver sells at £4.52 for 10 g and gold at £342 for 10 g, calculate the cost of a gold medal. (3 marks)

Cost of silver = $580 \text{ g} \times (\text{£}4.52 / 10) = \text{£}262.16$ (1 mark) (allow ecf from part ii).....

Cost of gold = $6 \text{ g} \times (\text{£}342 / 10) = \text{£}205.20$ (1 mark).....

Total = $\underline{\text{£}467.36}$ or $\underline{\text{£}467}$ (1 mark; correct answer with no working = 3 marks).....

10. This question is about polymers.

Polymers are very large molecules formed by joining together lots of small molecules called monomers.



One common polymer is polyethene.

This is formed by joining together lots of ethene molecules in a process called addition polymerisation.

The diagram below shows the process.

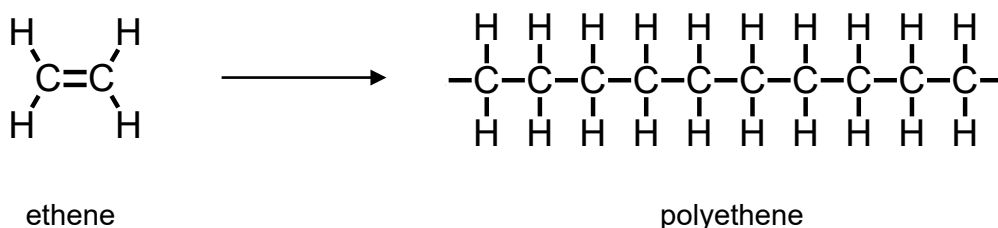

(a) State the chemical formula for a molecule of **ethene**. (1 mark)

C₂H₄.....

Instead of drawing out the whole polymer, you can draw a small part of it, called the **repeating unit**. The polymer is made up of this unit repeated over and over again.

(b) Which diagram correctly shows the repeating unit of polyethene? (1 mark)

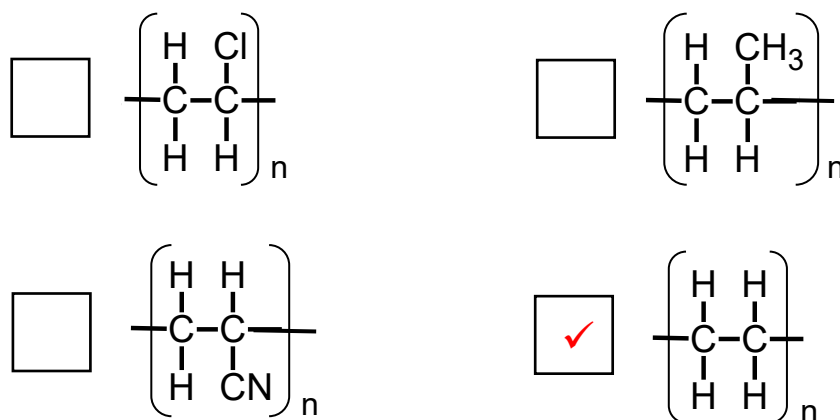

Another type of polymer is a **polyester**.

This is formed when a dicarboxylic acid reacts with a diol. The diagram below shows the reaction.

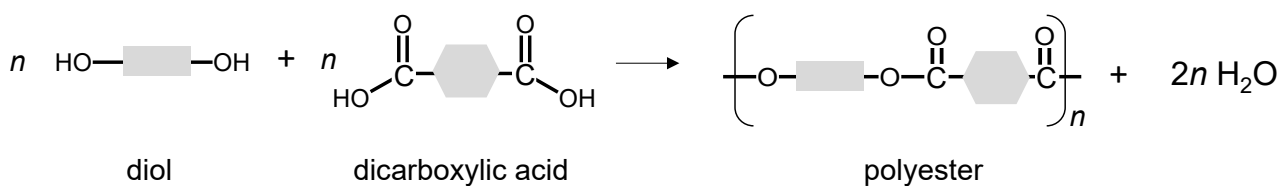

(c) i. Why is this type of polymerisation known as **condensation** polymerisation?

Water or a small molecule is lost or produced in the reaction (1 mark)

ii. Draw the repeating unit of the polyester formed when ethanediol reacts with propanedioic acid.

Use the example above for guidance. (2 marks)

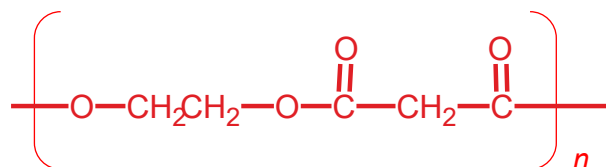
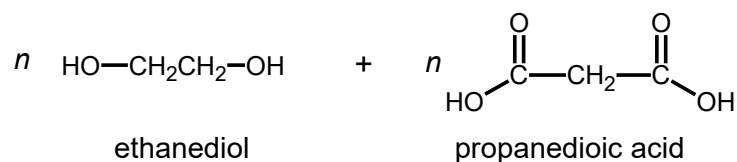

1 mark correct ester linkage in middle

1 mark correct remainder

NOTE 'O' can be either on left or right hand edge of repeating unit

Brackets and 'n' not required

(d) Kevlar® is another example of a condensation polymer.

It is extremely strong and is used for protective clothing such as bullet proof vests and cut resistant gloves.

Kevlar® is formed from the reaction of a diamine with a diacyl chloride. **In this case $2n$ molecules of HCl are eliminated.**

Draw the repeating unit of Kevlar®.

(2 marks)

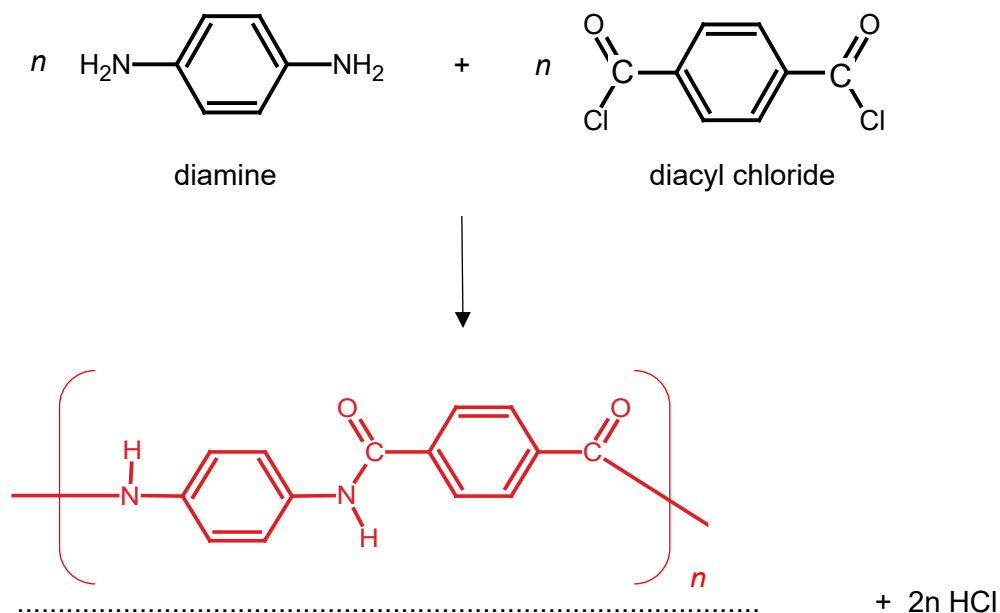

1 mark correct amide link in middle

1 mark correct remainder of structure

NOTE 'NH' can be either in the right or left hand edge of the repeating unit

Brackets and ' n ' not required

11. This question is about **allotropes** of carbon.
Allotropes are different forms of the same element.

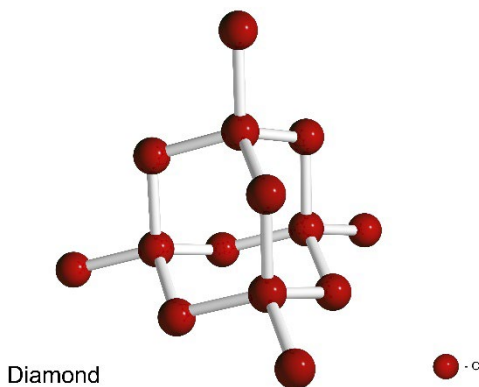

(a) The image shows the structure of one allotrope of carbon, **diamond**.
Use an understanding of the bonding in diamond to explain why it has a high melting point. (2 marks)

Need to break covalent bonds to melt it. (1 mark)

This requires a lot of energy / bonds are strong (1 mark)

or You need to break many strong covalent bonds (2 marks)

(b) Another allotrope of carbon is a **carbon nanotube**.

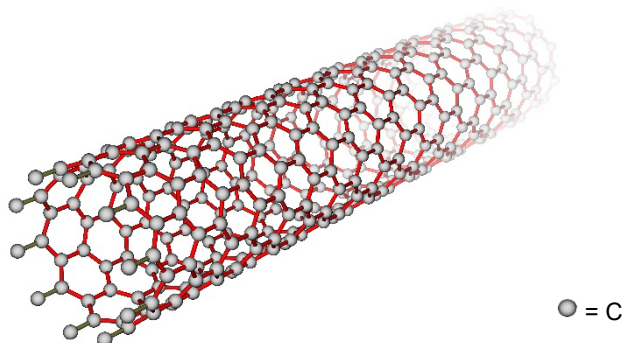

i. How many other carbon atoms is each carbon atom bonded to. (1 mark)

3

ii. Predict if carbon nanotubes conduct electricity.
Use an understanding of the bonding to explain why / why not. (2 marks)

Yes they conduct electricity (1 mark; must be correct to gain explanation mark)....

Only 3 electrons per carbon are used in bonding so each carbon atom
has 1 free electron to carry the charge (not just it has free electrons) (1 mark)

- (c) In 1985 Sir Harry Kroto and his co-workers discovered that C_{60} molecules could form spontaneously from a condensing carbon vapour.

The C_{60} molecules were named **Buckminster fullerene**.

The image shows a molecule of Buckminster fullerene.

This is often referred to as a bucky ball owing to the molecule having the same symmetry pattern as a football.

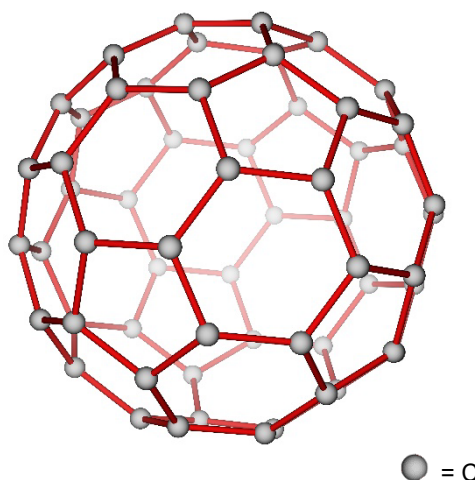

- i. A bucky ball has a diameter of 1.01 nm.
Express this diameter in units of metres using standard form. (1 mark)

$1.01 \times 10^{-9} \text{ m}$

- ii. Bucky balls are often used as a catalysts because they have a large surface area to volume ratio.

Calculate the surface area to volume ratio of a bucky ball. (4 marks)

The surface area of a sphere = $4\pi r^2$

The volume of a sphere = $\frac{4}{3} \pi r^3$

$\pi = 3.14$

Show all working.

$r = 1.01 \text{ nm} / 2 = 0.505 \text{ nm}$ (1 mark)

Surface area = $4 \times \pi \times (0.505 \text{ nm})^2 = 3.205 \text{ nm}^2$ (1 mark)

Volume = $4/3 \times \pi \times (0.505 \text{ nm})^3 = 0.5395 \text{ nm}^3$ (1 mark)

Surface area : volume ratio = $3.205 : 0.5395 = \underline{5.94 : 1}$ or $\underline{1 : 0.168}$ (1 mark)

Working must be shown

or if calculations completed in units of m

$r = 1.01 \times 10^{-9} \text{ m} / 2 = 5.05 \times 10^{-10} \text{ m}$ (1 mark)

Surface area = $4 \times \pi \times (5.05 \times 10^{-10} \text{ m})^2 = 3.205 \times 10^{-18} \text{ m}^2$ (1 mark)

Volume = $4/3 \times \pi \times (5.05 \times 10^{-10} \text{ m})^3 = 5.395 \times 10^{-28} \text{ m}^3$ (1 mark)

Surface area : volume ratio = $3.205 \times 10^{-18} : 5.395 \times 10^{-28}$

= $\underline{5.94 \times 10^9 : 1}$ or $\underline{1 : 1.68 \times 10^{-10}}$ (1 mark)

- (d) Scientists at the University of Manchester received the Nobel Prize for Physics in 2010 for experiments they had carried out on a third allotrope of carbon, **graphene**.

Graphene is a single layer of carbon atoms joined together in hexagons.

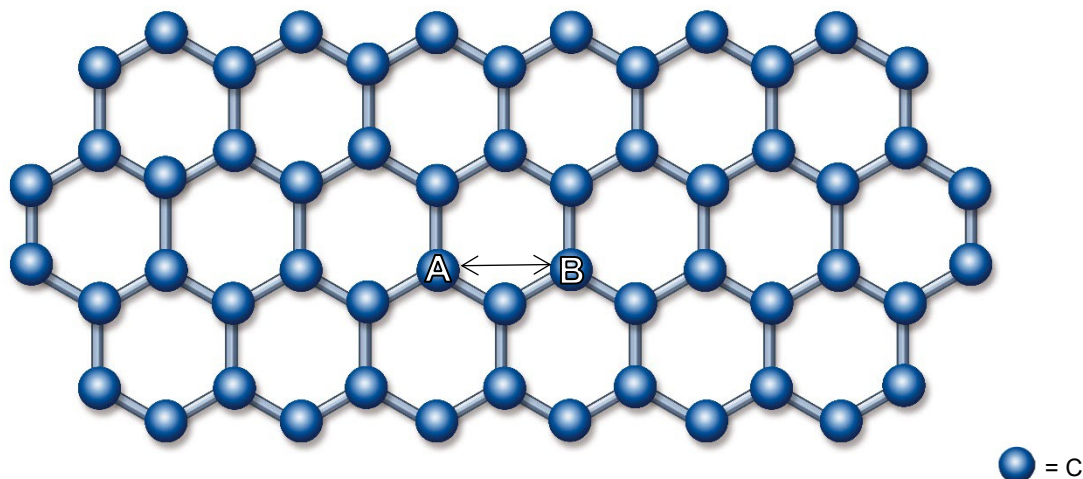

If the C-C bond length in graphene is 0.142 nm, calculate the distance across a single hexagon, labelled distance **AB** on the image. (3 marks)

There are a number of ways to complete this calculation;

1. Using pythagoras;

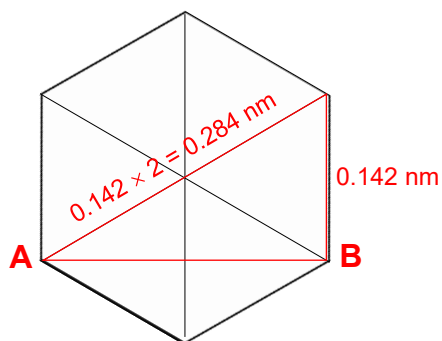

(1 mark for diagram)

$(0.284 \text{ nm})^2 = AB^2 + (0.142 \text{ nm})^2$ (1 mark)

$AB^2 = 0.060492 \text{ nm}^2$

$AB = 0.246 \text{ nm}$ (correct answer = 3 marks)

.....

2. Using trigonometry;

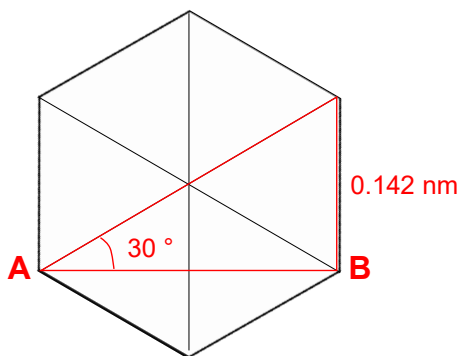

(1 mark diagram)

$\tan 30^\circ = 0.142 \text{ nm} / AB$ (1 mark)

$AB = 0.246 \text{ nm}$ (correct answer = 3 marks)

.....
.....