

14–16 years

Key terms accessible glossary: elements, compounds and mixtures



Education
Inspiring your teaching and learning

Downloaded from rsc.li/4j5xfyj,
teacher notes also available

Contents

For how to use, metacognitive prompts, ideas for support and challenge, and linked resources, visit: rsc.li/4j5xfyj

Chromatography

Chromatogram.....	4
Chromatography.....	5
Gas chromatography.....	6
Mobile phase.....	7
Paper chromatography.....	8
Rf value.....	9
Stationary phase.....	10
Thin layer chromatography.....	11

Mixtures and separation

Crystallisation.....	12
Evaporation.....	13
Filtration.....	14
Formulation	15
Fractional distillation.....	16
Separating funnel.....	17
Simple distillation.....	18

Contents

Representing elements and compounds

Chemical formula.....	19
Chemical symbol.....	20
Empirical formula.....	21
Molecular formula.....	22
State symbol.....	23

Solubility

Aqueous.....	24
Concentrated.....	25
Dilute.....	26
Precipitate.....	27
Saturated solution.....	28
Solubility.....	29
Solution.....	30

Chromatogram

the image that shows the results of separating a mixture by chromatography

In other words ...

the 'picture' result showing how different parts of the mixture have been separated using chromatography

Say it

Cro-mat-o-gram

Break it down

Chroma (colour), gram (record)

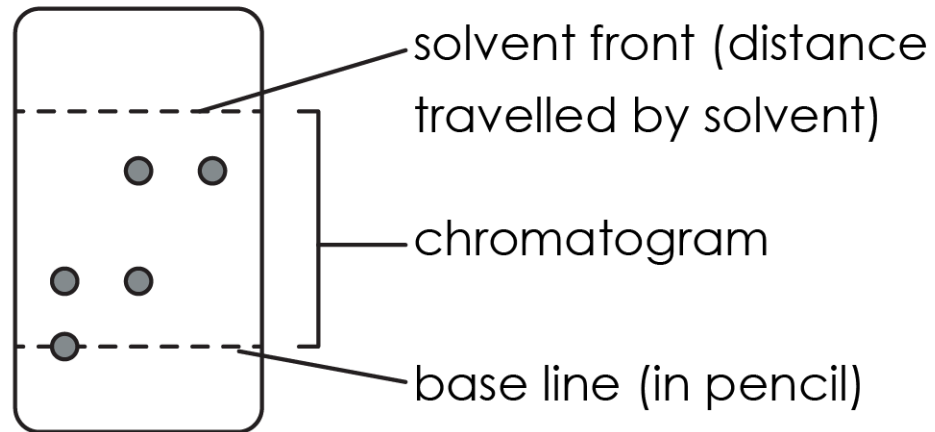

Example

The chromatogram revealed that the unknown ink contained dyes A and B

Don't confuse with ...

chromatography. This is the name of the process itself

Other contexts

Gram in everyday life refers to recorded information. This is where the name Instagram came from!

Chromatography

In other words ...

a way to separate different substances in a mixture by letting them move through a material at different speeds

a method of separation based on how easily each substance in a mixture is carried by a mobile phase (such as a liquid solvent) that is moving through a stationary phase (such as a porous solid, like paper)

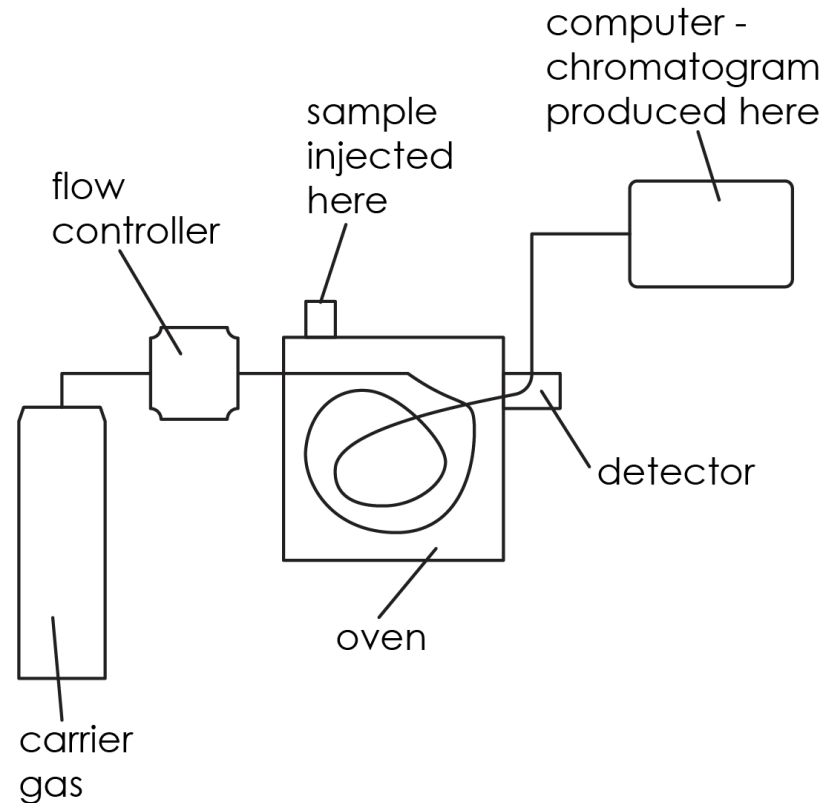
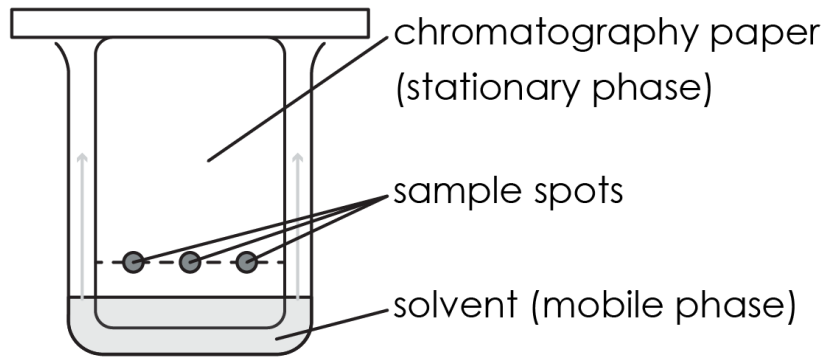

Example

We use chromatography to separate colours contained in inks

Break it down

Chrom (colours)

Say it

Cro-ma-tog-ra-fy

Gas chromatography

chromatography using a gas as the mobile phase, which passes through a column lined with a solid or viscous liquid as the stationary phase

In other words ...

a type of chromatography where a gas moves through a column to separate substances based on their interaction with material inside the column

Say it

Gas crow-ma-tog-ra-fy

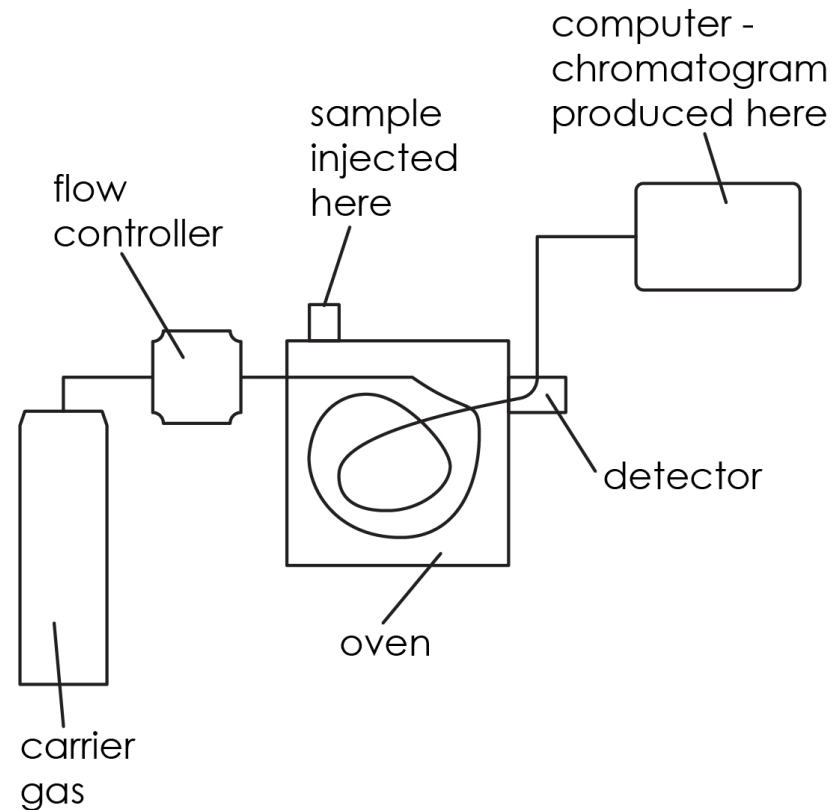

Break it down

Gas (mobile phase), chromatography (separation technique)

Example

Gas chromatography is used in the lab to identify different gases within a mixture

Don't confuse with ...

paper or thin-layer chromatography

Mobile phase

the liquid or gas solvent that moves through the stationary phase, carrying the substances that are being analysed with it

In other words ...

the liquid or gas which is mobile – it can move through the stationary phase

Say it

Mo-b-eye-l f-ay-z

Break it down

Mobile (moving),
phase (form)

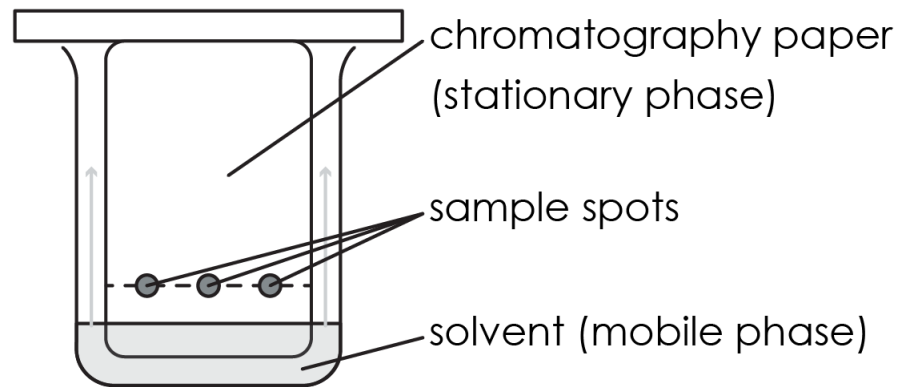

Example

The mobile phase in paper chromatography could be water if the dyes are soluble in water

Don't confuse with ...

stationary phase

Other contexts

Mobile refers to anything that is able to move, like a mobile phone or a mobility scooter

Paper chromatography

chromatography using a liquid solvent as the mobile phase, which soaks through paper as the stationary phase

In other words ...

a type of chromatography where a liquid solvent mixture moves through paper to separate the substances dissolved in it

Say it

Pay-pa cro-ma-tog-ra-fy

Break it down

Paper (material used), chromatography (separation technique)



Example

Paper chromatography can separate the individual dyes contained in food colouring

Don't confuse with ...

other types of chromatography. Like thin-layer or gas chromatography

Similar words

Often just called 'chromatography'

R_f value

the ratio of the distance moved by a compound to the distance moved by the solvent

In other words ...

$R_f = \text{distance travelled by sample} \div \text{distance travelled by solvent}$

Say it

R ef val-y-ue

Break it down

R_f stands for retention factor – how well the substance was retained (kept) by the stationary phase relative to the mobile phase

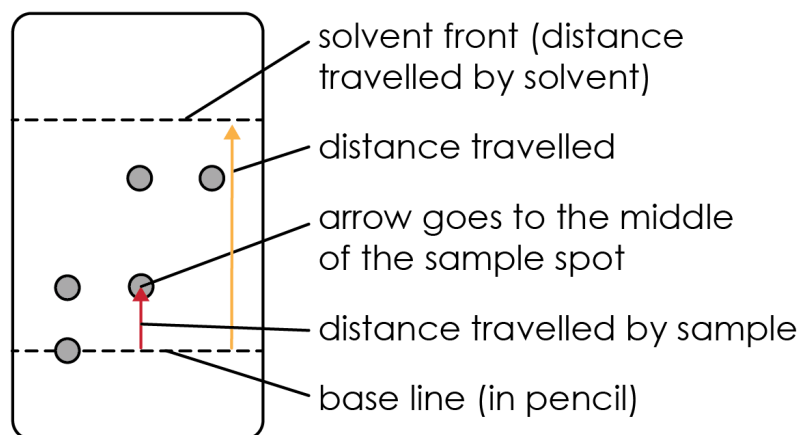

Example

The R_f value helped us to identify the dyes contained in the unknown

Don't confuse with ...

distance travelled. R_f is not just the distance; it is the ratio between the solvent and substance distances

Other contexts

Ratios are often used in everyday life to compare two amounts, for example recipe ratios

Stationary phase

is the material (such as the paper in paper chromatography) that does not move, but which the mobile phase flows through

In other words ...

the material in chromatography which remains stationary – it does not move. Other substances pass through it

Example

The stationary phase in paper chromatography is the paper itself

Say it

Stay-shen-ary f-ay-z

Break it down

Stationary (not moving), phase (form)

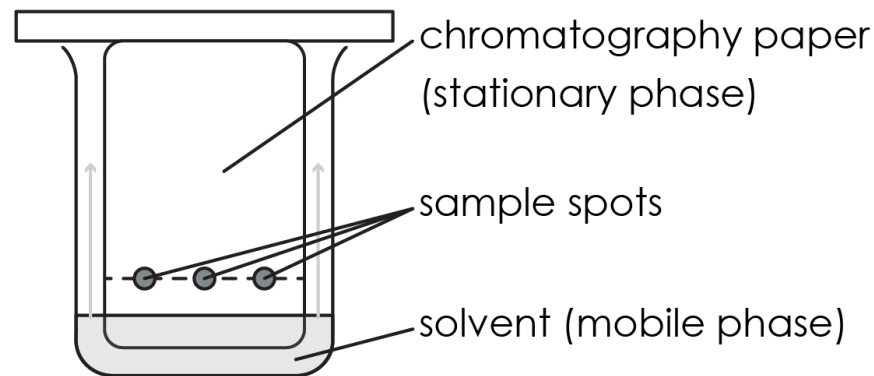

Don't confuse with ...

stationery! This spelling means 'writing and other office materials'

Other contexts

A stationary object is not moving

Thin layer chromatography

chromatography using a liquid solvent as the mobile phase, which soaks through a layer of silicon dioxide bonded on to a plastic or glass plate as the stationary phase

In other words ...

a type of chromatography where a liquid solvent mixture moves through a thin layer of material (like a plate) to separate the substances dissolved in it

Say it

Th-in lay-a crow-ma-tog-ra-fy

Break it down

Thin layer (small amount of material), chromatography (separation technique)

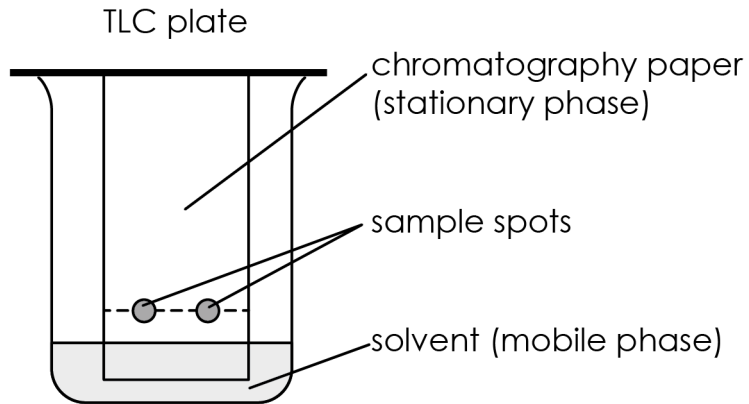

Example

Thin layer chromatography is often used in the lab to check purity

Similar words

Sometimes called plate chromatography

Don't confuse with ...

paper chromatography

Crystallisation

a method of separation used to get crystals of a solid by very slowly evaporating the solvent from a solution

In other words ...

when a dissolved solid forms crystals as the liquid part of the solution slowly evaporates

Don't confuse with ...
freezing

Say it
Cris-tel-eye-zay-shen

Break it down
Crystal (solid with a repeating pattern),
isation (process of making something)



Example

Rock salts form by crystallisation from seawater



Similar words

Solidification (but this can also relate to liquids freezing to form solids)

Evaporation

a method of separation used to form solids by heating to remove the solvent from a solution

In other words ...

a slow process where a liquid from a solution changes state into a gas, leaving any solids behind

Example

Water is separated from salty water by evaporation, leaving behind the solid salt

Sign it

Watch a video:



bit.ly/4k0GLU1

Say it

Eye-vap-a-ray-shen

Break it down

Evap (from Latin meaning 'turns to a vapour'), ation (the process)

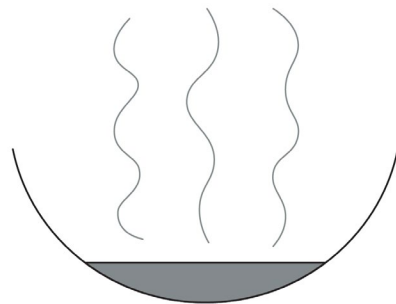

Don't confuse with ...

boiling. Evaporation and boiling are different processes. Evaporation can happen at any temperature, and is a slower process

Similar words

Vaporisation (relates only to the gas)

Other contexts

Wet clothes dry on the washing line by evaporation

Filtration

a method of separation used to remove an insoluble solid from a liquid

In other words ...

a method of separating a solid which is not dissolved from a liquid. The mixture is passed through special porous paper called filter paper

Sign it

Watch a video:

bit.ly/433R4z8



Say it

Filt-ray-shen

Break it down

Filtr (Latin *filtrum* meaning 'something used to strain'), ation (a suffix meaning 'the process of')

Example

Sand is not soluble in water, so filtration can be used to remove it. The sand remains in the filter, and the water passes through

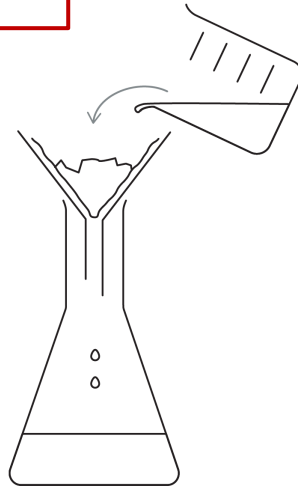

Don't confuse with ...

evaporation. Filtration cannot separate dissolved substances, like salt from water. Only insoluble solids can be removed from solutions in this way

Other contexts

Air filters remove dust from the air

Formulation

a mixture that has been designed as a useful product, made by mixing substances in carefully measured quantities, such as paint or medicines

In other words ...

a carefully planned mixture of substances in set amounts that has been created to serve a particular purpose

Say it

Form-ya-lay-shen

Break it down

Form (make), ulation (the process of making something)

Similar words

Recipe

Example

Medicines are formulated to help with a particular ailment

Don't confuse with ...

mixture. Not all mixtures serve a purpose or have components carefully added in measured amounts

Other contexts

Formulation can refer to how a product is made, like the formulation of skincare or cleaning solutions

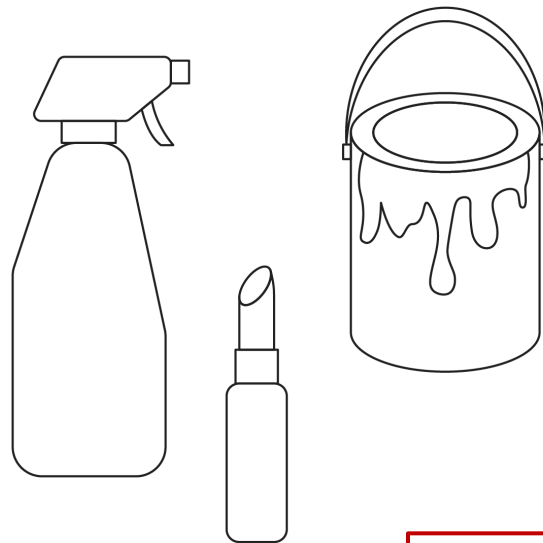

Fractional distillation

a method of separation involving continuous evaporation and condensation used to separate a mixture of liquids with different boiling points

In other words ...

separating liquids with different boiling points by evaporating the mixture and collecting each part as it condenses

Say it

Frac-shen-el dis-til-ay-shen

Break it down

Fractional (part or section),
distillation (process of separating liquids by evaporation and condensation)

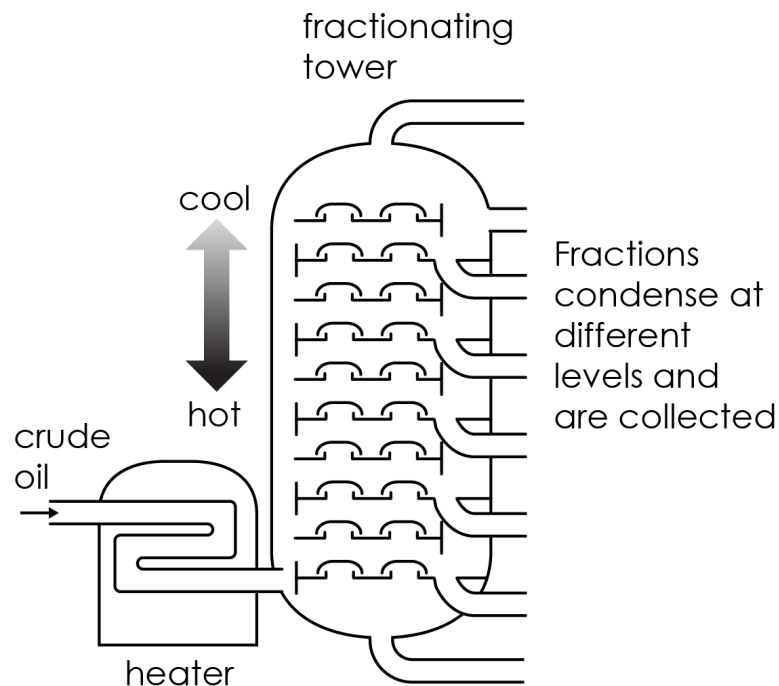

Example

Fractional distillation is a crucial method used to separate different components of crude oil into products like gasoline, diesel, and kerosene

Don't confuse with ...

simple distillation. Fractional distillation can separate multiple different components at the same time because of their different boiling points

Separating funnel

a container with a tap at the bottom used to separate liquids that are not miscible by running each layer out into different containers below

In other words ...

a tool with a tap used to separate two liquids that don't mix. Each liquid is allowed to flow out separately through the tap at the bottom

Say it

Sep-ar-ay-ting fun-el

Break it down

Separating (to divide), funnel (a tool used to pour liquids)

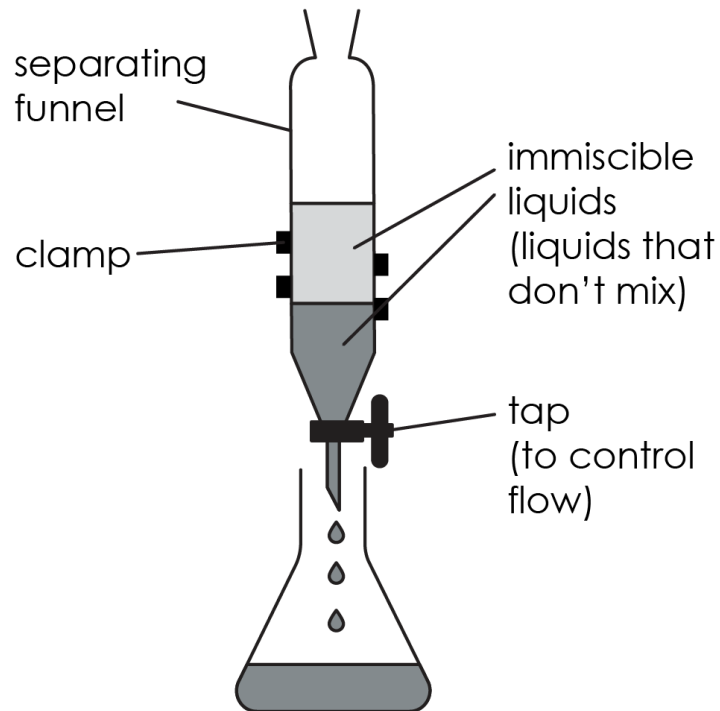

Example

A separating funnel can be used to separate oil and water

Don't confuse with ...

other separation techniques such as distillation. Separating funnels are specifically used for immiscible liquids

Other contexts

Separating immiscible liquids is often done in our everyday lives, but we rarely use a separating funnel at home!

Simple distillation

a method of separation involving evaporation and condensation that is used to separate the solvent from a solute that does not evaporate

In other words ...

a way to separate a liquid from a solution by heating it until it changes into the gas state, then cooling it to change back into the liquid state

Sign it

Watch a video:



bit.ly/4jJMAoA

Say it

Sim-pel dis-til-ay-shen

Break it down

From the Latin distil, meaning to drip down

Example

Pure water can be made from the distillation of seawater

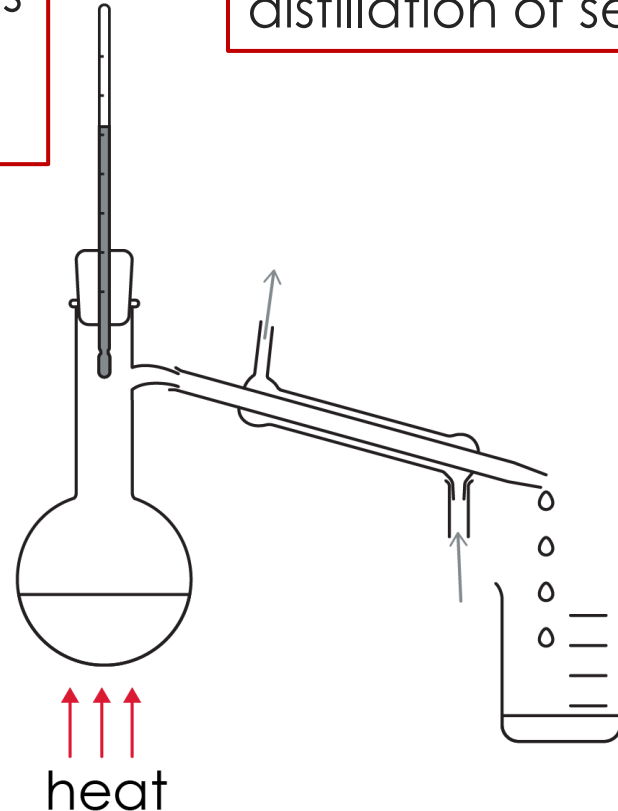

Don't confuse with ...

just evaporation. This process collects the liquid. Evaporation and condensation take place in distillation

Similar words

Distil

Chemical formula

uses chemical symbols to show the relative number of the atoms (or ions) of each element in a substance, such as H_2O for water or NaCl for sodium chloride

In other words ...

this type of formula gives the chemical symbols of the elements whose atoms (or ions) make up the substance. The formula also shows the relative numbers of these atoms (or ions)

Say it

Cem-i-cel form-ya-la

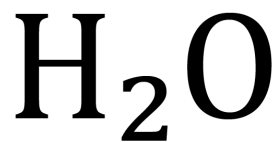

└──────────┘
2 x hydrogen
atoms

1 x oxygen
atom

Break it down

Chemical (relating to substances), formula (a set way of writing things)

Similar words

Molecular formula (for molecules)

Example

The chemical formula for water is H_2O , which shows that each molecule has two hydrogen atoms and one oxygen atom bonded together

Don't confuse with ...

balancing numbers or reacting ratios. Small, subscript numbers tell us how many atoms there are of the element whose symbol they follow

Other contexts

A formula can also mean a set of instructions, like a maths formula, or a recipe

Chemical symbol

a single letter or two letters that is used to represent an element, such as C for carbon, Na for sodium

In other words ...

a chemical symbol is a short way of writing the name of an element using one or two letters

Sign it

Watch a video:



bit.ly/3Z25eQ6

Say it

Cem-i-cel sim-bel

Break it down

Chemical (relating to substances), symbol (a sign or a letter to represent something)

Example

The chemical symbol for carbon is C

C

carbon

Na

sodium

Similar words

Element symbol

Don't confuse with ...

initials. Some elements have chemical symbols which match their name in English, e.g. O is for oxygen. Other elements, such as gold, Au, have unexpected chemical symbols, as their names derive from other languages

Empirical formula

uses chemical symbols to give the simplest ratio of atoms (or ions) of each element in a substance, such as CH_2 for ethene which has molecular formula C_2H_4

In other words ...

a way to show the simplest ratio of atoms (or ions) in a compound

Say it

Im-pir-i-cel form-ya-la

Break it down

Empirical (based on observation), formula (a way of representing something)

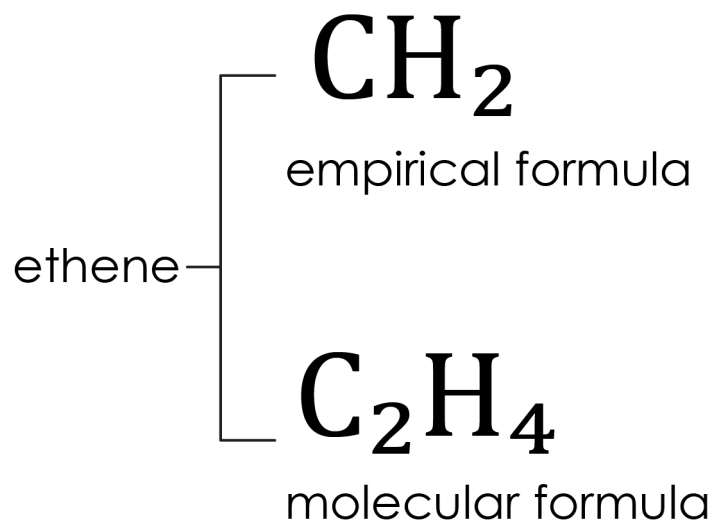

Example

Ionic substances have empirical formulas, such as NaCl , but we can also use empirical formulas to simplify for very large molecules. Glucose, for example, has the molecular formula $\text{C}_6\text{H}_{12}\text{O}_6$, and the empirical formula CH_2O

Similar words

Simplest whole number ratio

Don't confuse with ...

molecular formula – which shows the atoms in one individual molecule

Molecular formula

uses chemical symbols to give the number of atoms of each element in one molecule of the substance, such as N_2 for nitrogen or H_2O for water

In other words ...

a way to show how many atoms of each element are in one molecule of a substance, such as H_2O for water

Example

The molecular formula of carbon dioxide is CO_2 , showing that each molecule contains one carbon atom and two oxygen atoms

Say it

Mal-ec-ya-la
form-ya-la

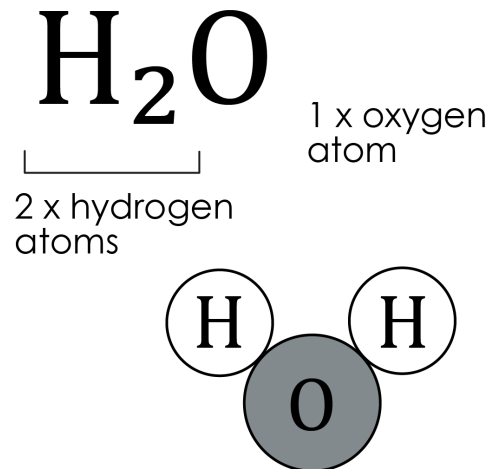

Don't confuse with ...

empirical formula – used for non-molecular substances, such as sodium chloride, NaCl , and graphite, C . These are not molecular formulas, as there are many more atoms present than shown in the formulas

Break it down

Molec (small unit),
ular (related to)
formula (a way of
representing
something)

Similar words

Chemical formula (but this can relate to single atoms, too)

State symbol

used sometimes with the chemical formula to show the states of substances, where (s) is solid, (l) is liquid, (g) is gas and (aq) is aqueous

In other words ...

a state symbol is a small letter in brackets that tells us whether a substance is in the solid, liquid or gas state or dissolved in water (aqueous)

Sign it

Watch a video: 
bit.ly/4iMfO4Q

Say it

St-ay-t sim-bel

Break it down

State (the form something is in), symbol (a sign or letter to represent something)

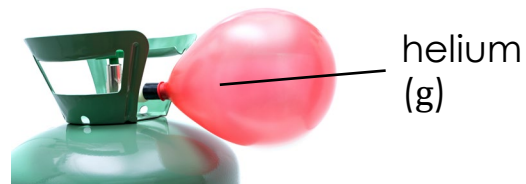
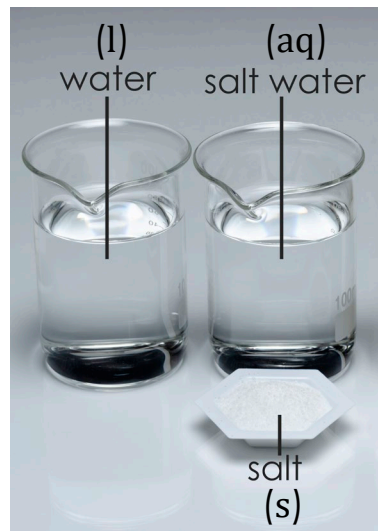

Example

In the reaction: $\text{H}_2(\text{g}) + \text{O}_2(\text{g}) \rightarrow \text{H}_2\text{O}(\text{l})$, the state symbols show that hydrogen gas and oxygen gas react together to form liquid droplets of water

Don't confuse with ...

physical appearance; (aq) and (l) are not the same – aqueous means the substance has dissolved into water to form a solution, while (l) shows that the substance is melted

Aqueous

when a substance is dissolved in water;
shown by the state symbol (aq)

In other words ...

aqueous means that something has been dissolved in water to form a solution

Say it

Ay-cw-ya-s

Break it down

Aqua (from the Latin meaning 'water'), ous (suffix meaning 'full of')



Similar words

Solution (a liquid mixture, often made with water)

Example

Saltwater is an aqueous solution of salt dissolved in water

Don't confuse with ...

liquid. (aq) and (l) are not the same – aqueous means the substance has dissolved in water to form a solution. (l) shows that the substance is melted. Pure water is a liquid, not an aqueous solution, so it should have the state symbol (l)

Other contexts

Aqua often is used for things related to water – aquariums and aquatic sports, for example

Concentrated

when there is a lot of solute dissolved in a particular volume of solvent

In other words ...

when a solution has lots of solute compared to the solvent

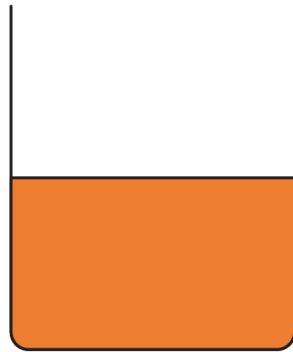

concentrated

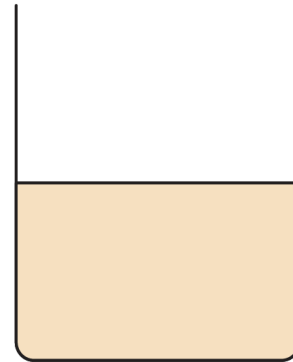

dilute

Example

We buy squash in a concentrated form, and dilute it by adding water

Don't confuse with ...

strength (of acids) – this is a separate term. Acids can be both concentrated **and** strong/weak

Say it

Con-sen-tray-tid

Break it down

Conc (with), centrate (to focus) which suggests that the solute is 'packed' or 'focussed' within the solution

Other contexts

Concentrated in everyday life often means more powerful, like a concentrated cleaning product

Dilute

when there is not very much solute dissolved in a particular volume of solvent

In other words ...

when a solution has a small amount of solute compared to the solvent

Say it

D-eye-lue-t

Sign it

Watch a video: 

bit.ly/4ikVJCq

Break it down

Di (apart), lute (loosen) which suggests the solute is 'spread out' in the solution

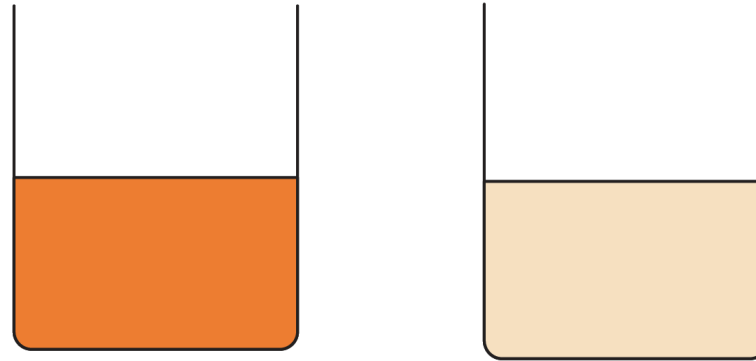

concentrated

dilute

Example

If you add more water to squash, it will become more dilute

Don't confuse with ...

weak (acid) – acids can be concentrated **and** strong/weak

Other contexts

Dilute in everyday life means to lessen or weaken something, like diluting a cleaning product by adding water

Precipitate

an insoluble solid that is formed within a solution during a chemical reaction between two soluble substances

In other words ...

a solid that forms from the reaction of two solutions

Say it

Pri-sip-i-tat

Break it down

Pre (before), cipit (fall) suggesting the solid 'falls' out of the solution

Similar words

Precipitation is a word used to describe rain 'falling'



Example

When testing for halide ions, a precipitate will form between the solution and silver nitrate solution

Don't confuse with ...

solute. Solutes are soluble, but precipitates are insoluble

Saturated solution

when no more solute can dissolve in a particular volume of solvent at that temperature

In other words ...

a solution where no more solute can dissolve because it has reached its limit at that temperature

Say it

Sach-ar-ay-tid
sal-ue-shen

Break it down

Satur (soak), ated (full)
which suggests the solution is 'full' of solute

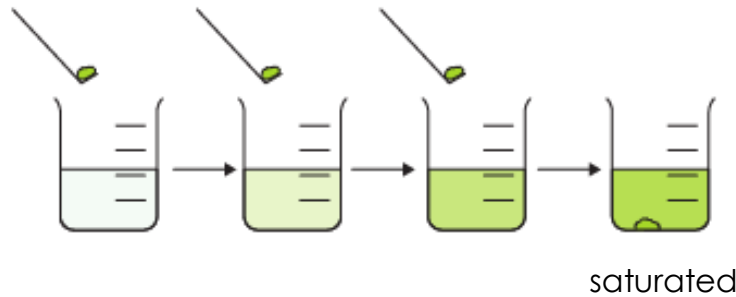

Example

If you keep adding salt to water and it stops dissolving, you have made a saturated solution

Don't confuse with ...

concentrated solution.
Something can be concentrated, but may not necessarily be saturated

Other contexts

In everyday language, something which is saturated could be completely soaked, like a sponge saturated with water. Like the salt solution, it cannot contain any more water

Solubility

the maximum mass of a solute which can be dissolved in 100 grams (g) of solvent at a particular temperature

In other words ...

the maximum amount of substance that can dissolve in a certain volume of solvent at a specific temperature

Sign it

Watch a video: 

bit.ly/4m4h3iz

Say it

Sol-ya-bil-aty

Break it down

Sol (dissolve),
ubility (ability)

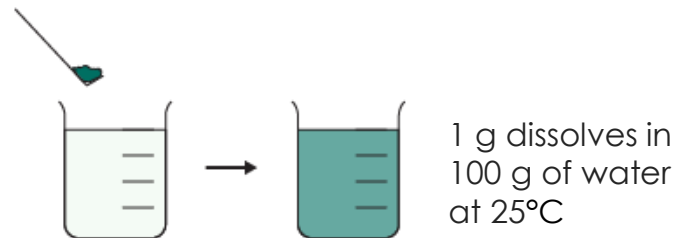
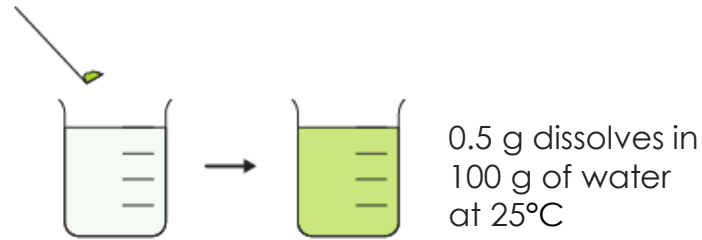

Similar words

Dissolvability

Example

The solubility of sugar is higher when the water is warmer

Don't confuse with ...

saturation. Once a solution has reached its maximum solubility, it then becomes saturated

Other contexts

We use this term generally to describe a solute's ability to dissolve, where the more soluble means more easily dissolved

Solution

In other words ...

a mixture where one substance dissolves completely in another, such as salt in water

Sign it

Watch a video:



bit.ly/44uofhF

Say it

Sal-ue-shen

Break it down

Sol (dissolve), ution (process)

the mixture produced when a solute dissolves in a solvent

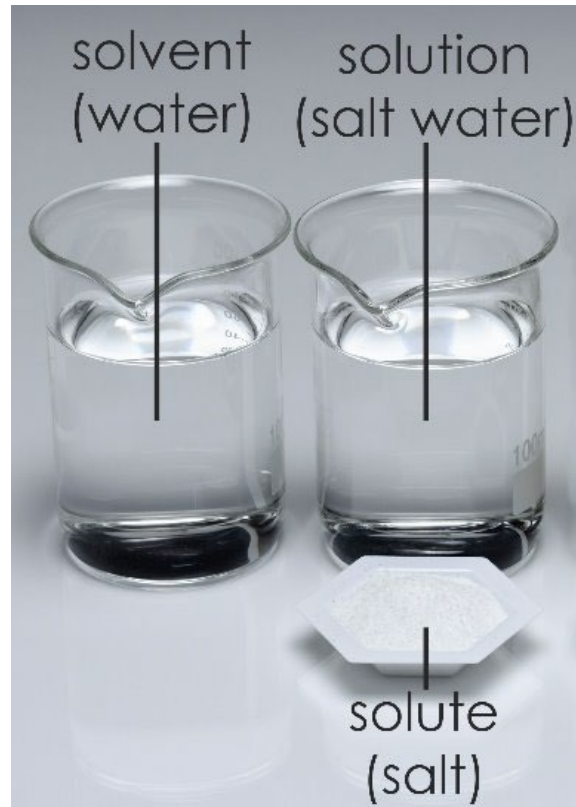

Example

In a solution of salt water, the solute is salt and the solvent is water

Don't confuse with ...

aqueous. Solutions are often formed in water, but they can form in other liquids, too

Other contexts

The way to solve a problem, especially in mathematics

Similar words

Sometimes sterile salt solution is called 'saline'

Acknowledgements

Images on slide 12, 24 and 27 © Shutterstock

Image of copper sulfate powder on slide 24 © Fablok/Shutterstock

Image on slide 23, 30 © Turtle Rock Scientific/Science Photo Library

Image on slide 23 © Getty Images

All other images © Royal Society of Chemistry

SSC BSL Glossaries of Curriculum Terms

(<https://www.ssc.education.ed.ac.uk/BSL/>)